

Reflections on a Year With Cristofori Part 1

FARTHOLOMÆUS DE CHRISTOPHORIS PATAVINVS INVENTOR FACIEBAT FLORENTIAE
MDCCLXXII

Smithsonian Institution Photo by Hugh Tallman

By Edwin M. Good
Smithsonian Institution

Two large, white crates stood on the floor in the Smithsonian Institution's International Gallery in early March, 2000. Awaiting the opening of the Smithsonian's *Piano 300* exhibit were pictures and graphic reproductions on walls, pianos on platforms with their explanatory labels on rails, cases with books and manuscripts.¹ Next to the crates stood a platform, with its parquet floor and its alarm, ready to receive the exhibit's principal jewel. Curators, installers, and administrators attached to *Piano 300* surrounded the crates. The crates were opened, and as a small, plain piano and its stand were taken out, there was an audible collective drawing of breath. As one curator put it

(and another hereby testifies from personal experience), "there wasn't a dry eye in the place."

We were looking at the Cristofori piano borrowed for the exhibit from the Museo Nazionale degli Strumenti Musicali in Rome. According to the nameboard inscription, Cristofori made it in Florence in 1722. Alessandro Marcello (1669-1747: brother of the more famous Benedetto, 1686-1739) bought it a year or so later, and it had come to the museum in Rome in 1966.² It stayed in the Smithsonian exhibit until Feb. 20, 2001, when it was returned to Rome.

Placed on its platform, it became irreversibly a part of our lives. We looked at it and thought about it every time we

went to the gallery, talked about it and its meaning whenever we gave tours of the exhibit, hovered over it as fortepiano and harpsichord builders Thomas and Barbara Wolf measured, examined, and photographed it in the process of making a copy, for which they were commissioned.³ Even now, we cannot stop thinking about it, looking at the pictures, mentally revisiting the experience of living with a genius (see photo on cover of this month's *Journal*).

One learns a great deal from a genius, even when genius does not rub off. Some of what I learned from Cristofori was new information, and some of it I learned in new ways. Trained in the humanities, I have always loved and depended on words, which our culture has generally assumed are the best way to teach and to learn. But with Cristofori, I had the piano, which is not only nonverbal but also mute.⁴ When one learns how to do it, one can, in a more than metaphorical way, "read" a piano, as one can read any object. But of course, there were hours of words, talk and more talk, among our colleagues.

We know little about Bartolomeo Cristofori's life. Born in Padua in 1655, he was employed from 1688 in Florence by Prince Ferdinando de' Medici, the Grand Prince of Tuscany, to make and maintain harpsichords. After Ferdinando's death in 1713, his father, Cosimo III de' Medici, the Grand Duke, employed Cristofori as the keeper of the Medici instruments. Various documents spell his name differently: Cristofori, Cristofari, Cristofali, which Scipione Maffei called him in his famous article of 1711,⁵ Cristofani, the name on his baptismal certificate.⁶

The crucial point in any case is the 1722 piano, and what we can extract from it about Cristofori's accomplishments and his thinking. Stewart Pollens describes it technically in his book (See note 5), and Thomas and Barbara Wolf will publish the material from their copying process. We found a few things in the Rome piano that Pollens did not mention.

The piano proves the often-stated claim, that Cristofori was a genius. His work, not only with the piano but in his harpsichords and clavichord as well, demonstrates an inventive imagination that places him well past other instrument makers of his time. To be sure, he must have worked with his head too, but we can get at his head only, as it were, through his hands. We have things he made, not words he wrote.

We do have one very interesting source for his ideas. Maffei's article was couched for the most part in Maffei's words, though we have come to realize that he sometimes quoted Cristofori without attributing the words to him. He

interviewed the inventor in 1709 in preparation for his article, and his notes from the interview have come to light.⁷ Here we may suppose we are close to Cristofori's own ideas. Much of the document is taken up with problems of tuning and of how the violin is the perfect instrument because it can play perfectly in tune. Violinists, of course, know that, and they have pungent things to say about the piano. But the notes tell us very little about how the inventor worked out his ideas, only that he did it, as Maffei's first note says, *senza motivo avuto da altra cosa*, "without any outside help" (Pollens's translation). For some time, scholars (including me) supposed that Ferdinando, who was enthusiastic about opera and about music generally, encouraged Cristofori to think about a keyboard instrument that could do what the wonderful Italian singers and violinists did with expressive variation of dynamics. With his remark, Cristofori neatly excluded Ferdinando, from the picture, almost as if he knew that someone somewhere would give the Prince the credit for the invention, whereas Maffei's article would prove the Paduan inventor's self-motivation.⁸ Did he think of Maffei as a press agent? Then he was not only a genius but a modern man.⁹

And invention it was. I have said in print that Cristofori simply tinkered with the harpsichord. Even in the recent second edition of *Giraffes, Black Dragons, and Other Pianos*, I said timidly only, "Cristofori may have known he was inventing a new instrument."¹⁰ I am now convinced that he did know he was inventing a new instrument. He said so: on his nameboards he called himself "Bartolomeo Cristofori, Paduan, inventor." Every problem of a hammer-action stringed keyboard instrument – except one, to which I will return – is brilliantly solved, none merely papered over by doing it as if the instrument were a harpsichord. The great new feature, of course, was the variation of dynamics, moving expressively from soft to loud and back again. The harpsichord could do that only within very stringent limits. You could not, except by wishing it inside your head and hearing it there, coax a crescendo or diminuendo out of the harpsichord. You could with the clavichord, but the clavichord's range of dynamics went from soft to nearly inaudible. To be sure, both Stewart Pollens and Conny Restle have given evidence of earlier hammer keyboards.¹¹ But those had no offspring, nor is there any evidence that Cristofori knew of them. His instrument produced progeny.

One stringed keyboard instrument might be a candidate for influence. In the late sixteenth century Hans Haiden (1536-1613) invented the *Geigenwerk*, a keyboard instrument



Figure 1 — Woodcut of Haiden's Geigenwerk from Praetorius, *Theatrum instrumentorum*, 1620. The pinblock is in five rounded sections, corresponding to the five rosined wheels, which revolve by use of the treadle mounted on the front leg. The instrument's name comes from the fact that the wheels, like violin bows, make the strings vibrate by friction, and Geige is the German word for violin.

whose keys pressed its gut (later metal) strings against parchment-covered and rosined wheels rotating at right angles to the strings. The player could produce crescendo and diminuendo by pressing harder on the keys, while making the wheels revolve by use of a treadle (see Figure 1). We know that Cristofori was acquainted with the *Geigenwerk*. One of Haiden's instruments came from his son David to Prince Ferdinando's grandfather, Archduke Ferdinando II, and at some time after 1670 it came to Ferdinando. It is listed in the inventory of Medici instruments that Cristofori drew up in 1716, when he was keeper of the instruments.¹² Evidently, Cristofori did not finally adopt the *Geigenwerk's* principle, imitating the bows of violins and cellos. He probably knew Haiden's machine before his work on the piano, and it might have encouraged him to think of the possibility of producing *piano* and *forte*

and gradations between them with a keyboard instrument. Cristofori worked on an entirely different principle.

The action, of course, is what we think of as the heart of it – and I wonder whether Rosamond Harding's marvelous attention to action design has influenced us in that way.¹³ Moreover, our culture's mechanistic approach to knowledge in general and science in particular has taught us to think about mechanisms. I have no wish to underplay that; I am the one who has called attention to the fact that the piano is a machine.¹⁴

Interestingly, Cristofori commented very little on the action in his conversation with Maffei. There must have been talk of it, as Maffei included in his article that superbly lumpy diagram of the action (see Figure 2). He either made the drawing from his own observation or had some discussion with the inventor about it. Only the last of Maffei's

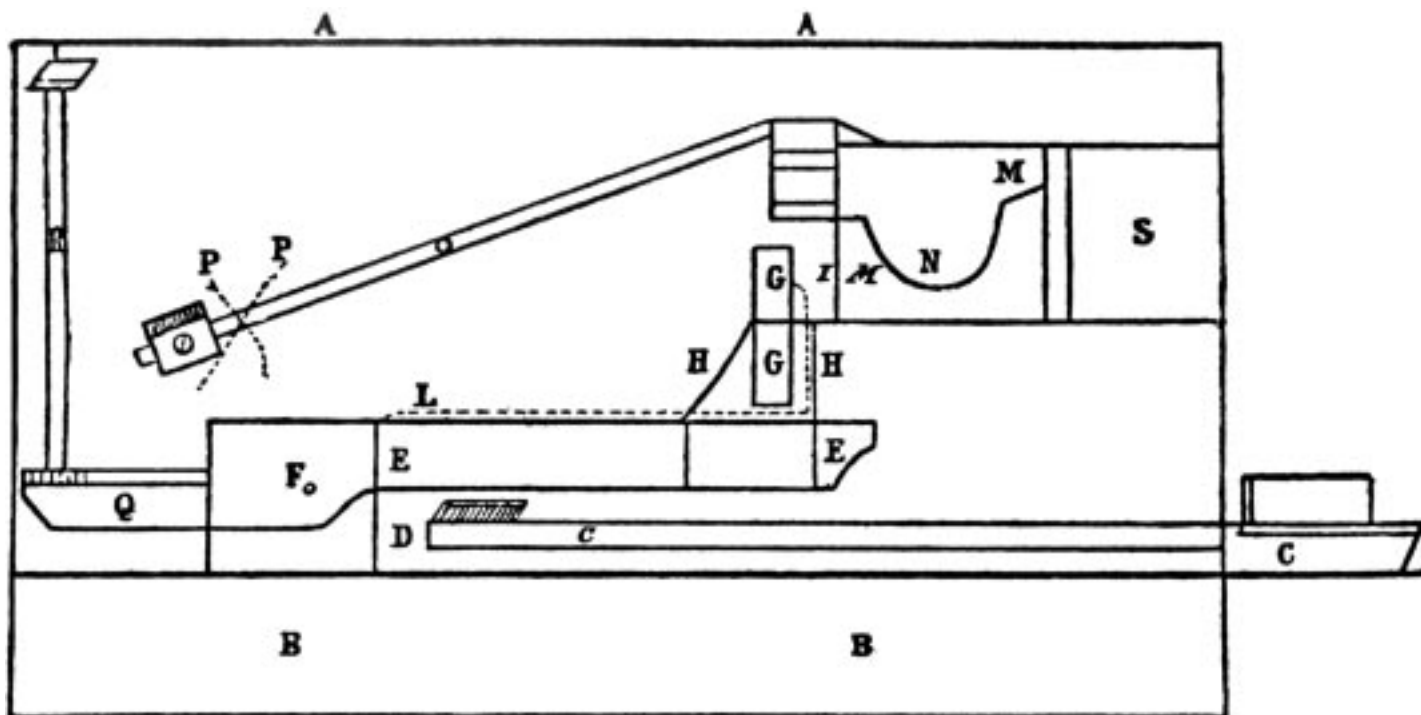

Figure 2 — Action drawing by Scipione Maffei from his article in the *Giornale de' letterati d'Italia*, 1711.

notes refers to the action. It is worth quoting and commenting on: "It is in having observed the difference of the motion of engagement of [...] toward the center, and placed near the circumference. When it is pushed upwards near the center every smallest impulse makes it go up, and if it is pushed with force it goes up with much pressure. Etc." (*Stannell' aver osservato la differenza del moto d'ingaggio di [. . .] verso il centro, e posto vicino la circonferenza. Quando è spinto in sù vicino al centro ogni piccoli.^{mo} impulso lo fà salire, e se è spinto con forza va su con moltis.^o impeto. ec.*)¹⁵ Unfortunately, we cannot know what word or words were in the lacuna. I wish it said "hammer," and it probably did, as Maffei partly quoted this note in his article. "The hammer receives its blow near its pivot," he wrote, "which is to say, near the center of the path through which it moves, and therefore even a slight touch will make it move through a circle." Cristofori discovered that the best leverage from key to hammer results when the hammer is propelled at a point close to the pivot, rather than out near the circumference where the hammer head is. Near the center of the hammer's arc, the least downward motion of the finger on the key and the smallest upward motion of the hopper produce proportionately the largest motion of the hammer head. The placement of the bearing point of the intermediate lever on the hammer butt is one of the keys to the action. Cristofori's discovery of that leverage was part of his discovery that the loudness of the tone depended on the speed (or "pressure" or "impetus," *impeto*) with which the hammer struck the string. A harder push on the key makes the hammer rise "with much pressure" (*con moltis.^o impeto*, perhaps "with the most pressure or impetus," as *moltis.^o* doubtless abbreviates *moltissimo*). Maffei did not

refer to Cristofori's other discovery, that in order to produce the differentiation of soft and loud, the hammer had to fly free to the string and bounce back, instead of being pushed against the string like the clavichord's tangent or pushed past it like the harpsichord's jack with its plectrum. If it were pushed against the string, we would hear not a clear musical tone but a thump.

The hammer's flight around its pivot is, of course, a commonplace today. And it was doubtless a commonplace then for players of hammer dulcimers and the like, who were always pictured holding the mallet at the end opposite to the striking head. They got the most motion of their mallets from the smallest motion of their hands. Did Cristofori know dulcimer players? Did he hear Pantaleon Hebenstreit himself?¹⁶ I know of no evidence that he did either.¹⁷ And he would not have learned the wisdom of this leverage from the harpsichord or the clavichord. Both the harpsichord jack and the clavichord's tangent sit at the back end of the key, at the circumference of the key's circular motion. The downward motion of the player's end of the key is exactly proportional to the upward motion of the jack or tangent, the proportion being determined by the placement of the balance pin on which the key pivots. In the piano, the leverage takes advantage of the speed or weight of the player's touch to produce the desired tone and volume by affecting the speed with which the hammer flies to the string (see Figure 3).

In his pianos, Cristofori set the adapted harpsichord jack that raises the damper on the back part of the key,¹⁸ and he placed the escapement hopper some distance toward the back of the key from the balance pin: 110 mm in the 1722

CRISTOFORI 1722

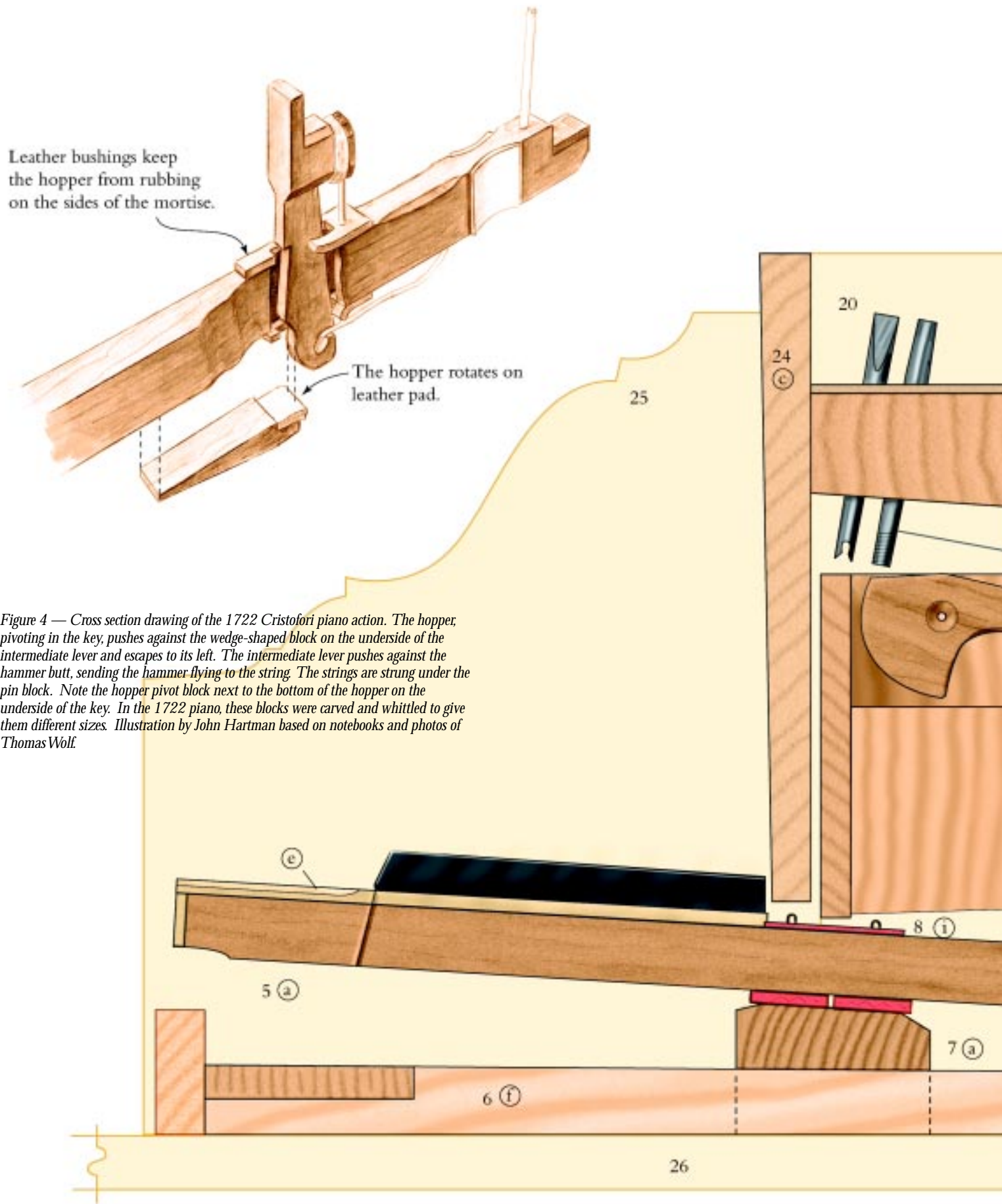
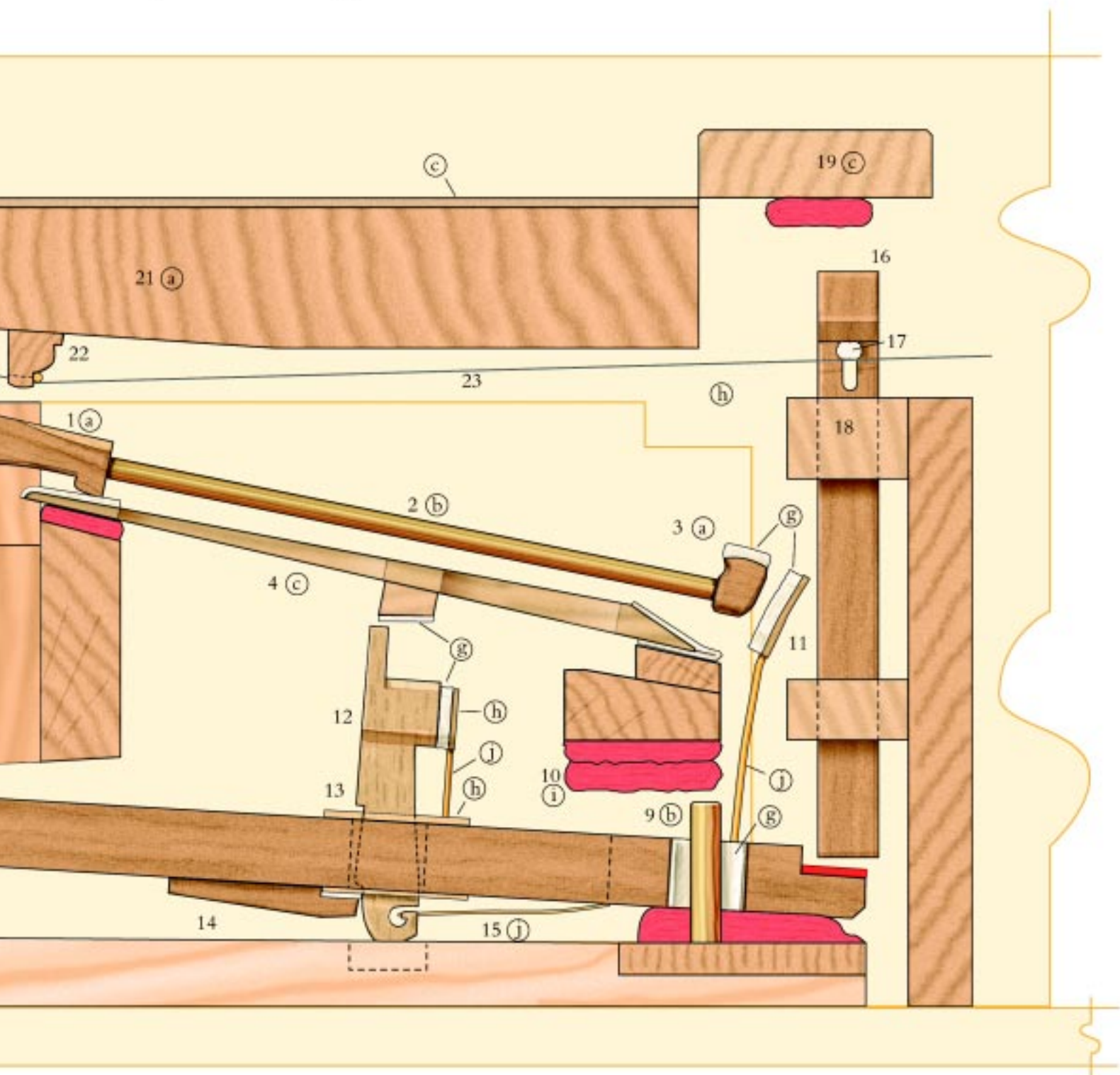

Figure 4 — Cross section drawing of the 1722 Cristofori piano action. The hopper, pivoting in the key, pushes against the wedge-shaped block on the underside of the intermediate lever and escapes to its left. The intermediate lever pushes against the hammer butt, sending the hammer flying to the string. The strings are strung under the pin block. Note the hopper pivot block next to the bottom of the hopper on the underside of the key. In the 1722 piano, these blocks were carved and whittled to give them different sizes. Illustration by John Hartman based on notebooks and photos of Thomas Wolf.

- | | | |
|----------------------|-------------------------|-----------------|
| 1 Hammer Butt | 10 Key Stop Felt | 19 Jack Rail |
| 2 Hammer Shank | 11 Backcheck | 20 Tuning Pins |
| 3 Hammer Head | 12 Hopper | 21 Wrest Plank |
| 4 Intermediate Lever | 13 Hopper Bushing | 22 Nut |
| 5 Key | 14 Hopper Pivot block | 23 String |
| 6 Keyframe | 15 Hopper Return Spring | 24 Name Board |
| 7 Balance Rail | 16 Jack | 25 Scroll |
| 8 Key Bushing | 17 Damper Leather | 26 Bottom Board |
| 9 Key Guide Dowel | 18 Jack Guide | |

- Materials:
- | | |
|--------------|-------------|
| (a) Walnut | (h) Leather |
| (b) Spruce | (i) Cloth |
| (c) Cypress | (j) Brass |
| (d) Poplar | |
| (e) Boxwood | |
| (f) Pine | |
| (g) Buckskin | |



Cristofori 1722 Hammer Shank Assembly

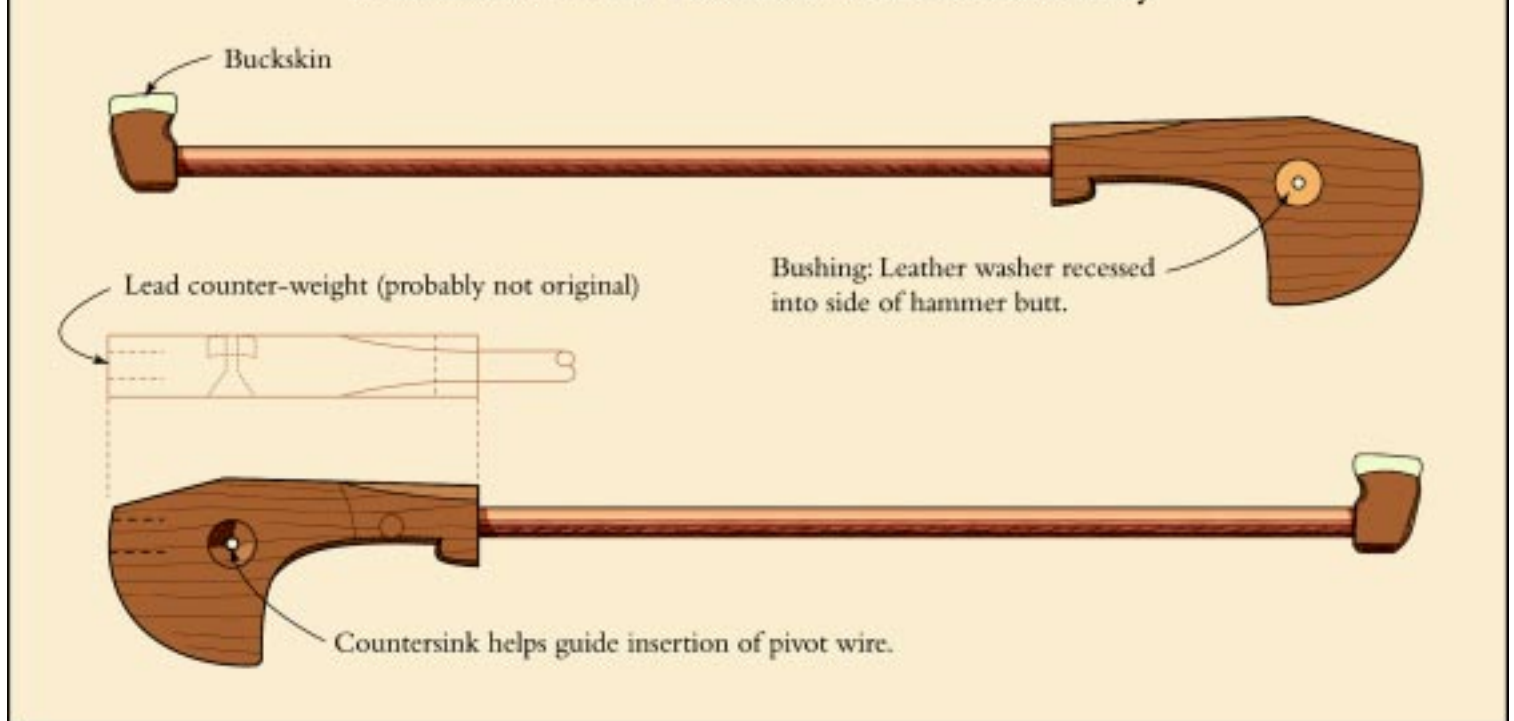

Figure 3 — Hammer assemblies from the 1722 Cristofori piano. Unlike hammers in the other two existing Cristoforis, the butts of this one are cut out in a shape that would fit a dulcimer player's finger, though the cut was probably made to give the correct weight. The almost square hammer head (it is actually slightly rounded) with a pad of leather at the strike point is shaped like the hammer head in Maffei's drawing. Illustration by John Hartman based on notebooks and photos of Thomas Wolf.

piano, approximately 70.5 percent of the bottom key length (332 mm), 73 percent of the top key length (320 mm).¹⁹ (see Figure 4). As the hopper is slightly closer to the fulcrum than is the front end of the key, its motion is slightly less than that of the key dip, but it propels the hammer to considerably greater motion and greater speed because of the leverage advantage. It strikes the intermediate lever at a point slightly below its middle (62 mm of 130 mm), so that the motion of the intermediate lever is barely more than that of the key. But the intermediate lever propels the hammer at just 33 mm from the pivot point, which, with a hammer shank length of 115-116 mm (top key to bottom key), is about 28.6 percent of the length from pivot to hammer head. That considerable leverage advantage illustrates Cristofori's remark: "When it is pushed upwards near the center every smallest impulse makes it go up, and if it is pushed with force it goes up with much pressure." Cristofori must have experimented with the placements of the balance pin of the key, the hopper in the key, and the contact block on the underside of the intermediate lever, as they differ to some extent in the existing actions.²⁰

These geometrical and mechanical details bring up a fascinating coincidence. Cristofori went to Florence in Ferdinando's employ at the age of 33 in 1688. In 1687 was published one of the seminal documents of Western science, Isaac Newton's *Principia Mathematica*, in which, among other things, Newton set forth the laws of mechanical motion. We

do not know whether Cristofori had any acquaintance with Newton's ideas of motion. Maffei was a member of one or more Italian Academies, societies of intellectuals who met to discuss the new ideas of the day, among which was certainly Newton's mechanics. It is almost surely only a coincidence that Cristofori's action design is a parade example of Newton's Second Law of Motion – that force on an object causes it to accelerate. The finger goes down on the end of the key, the other end of the key rises, and the hopper pushes the intermediate lever up against the hammer butt, the hammer is forced to revolve around its pivot and flies to the string, the string vibrates, and music is the result. The piano action applied a new kind of motion to the problem of causing stretched strings to vibrate. It embodied, but probably not by the inventor's conscious design, new scientific thinking in mechanics. Almost surely, Cristofori was completely ignorant of Newton and his works. Indeed, if he was, his genius is all the more impressive, for all by himself, *senza motivo avuto da altra cosa*, he utilized, perhaps stumbled on, a principle of mechanics first stated within his own lifetime by one of the prime geniuses of Western science. But what he says about his action has no particular similarity to the abstraction of Newton's law. It is a statement about a machine he made and how it works.²¹

In examining the action of the Rome piano with Thomas and Barbara Wolf, David Sutherland, and some others, we saw something that no one had previously

documented. The hopper projects through the key, and on the bottom of the key next to it on the side toward the player, is a wooden block, shaped roughly, as a friend remarked, like an upside-down whale. Its principal function is to provide the pivot for the hopper's motion in escapement.²² We were surprised to notice that these blocks had different sizes and shapes and gave signs of having been carved and whittled. Scratching our heads as to why they would be made of different sizes, we hypothesized finally that it might have to do with achieving a balance of touch weight. A few days later, the Wolfs brought in weights and a fulcrum, and discovered that we were right: the touch weight was beautifully balanced from one end of the keyboard to the other, slightly heavier in the bass to compensate for heavier strings and dampers, and the balance corresponded to the size of those blocks. The Wolfs had carefully examined the Leipzig instrument, and its corresponding blocks are all the same size.

It is, of course, terribly interesting that Cristofori was concerned with the weight of touch. As it is the means by which the player can consistently produce accents, crescendos, diminuendos, and other aspects of expressive playing, a well-balanced touch across the keyboard is of the essence. Harpsichord makers attempted to provide a balanced touch, often by carving the key levers, sometimes with lead weights, and it helped good, smooth playing, even though the player's touch cannot affect loudness or tone quality. Cristofori came to understand the demands of performing *on the piano* and brilliantly solved the problem.²³

But why did Cristofori sometimes, as in the 1722 piano, use the blocks to achieve a balanced touch and sometimes, as in the 1726 one, did not? I can only hazard a guess. In the 1722 piano, the distance from the key's balance pin to the hopper is the same in the bottom and the top keys, 110 mm (4.4 in.) (Pollens's measurements), suggesting that the distance is the same in all the other keys as well. Of course, the accidental keys are shorter and their balance pins are farther back on the balance rail than the naturals, but we can suppose that the distance between balance pin and hopper is the same in all of those keys, though different from Pollens's 110 mm. That distance affects the touch, of course: the farther toward the back of the key the hopper is mounted, the heavier the touch will feel. In the 1726 piano, the distance is different in the top and bottom keys, respectively 111 and 116 mm (4.4 in. and 4.6 in.) on keys respectively 344.5 and 336 mm (13.8 and 13.4 in.) (again, Pollens's measurements). The bottom key will be slightly heavier in touch. In a 1725 action, recently given to the Conservatorio "Luigi Cherubini" in Florence, the difference is also 5 mm (0.2 in.), 108 (10.3 in.) on the top key, 113 (4.5 in.) on the

bottom.²⁴ Given that the blocks in the Leipzig instrument are all the same size, it would seem that Cristofori achieved a balanced touch weight by the placement of the hoppers in the keys, rather than by carving the hoppers' pivot-blocks. Either way works, it would seem, and we cannot say why he used one method in one instrument and another method in another.

The solution to touch weight is not the only instance of such changes. Cristofori certainly changed his mind between designing the action that Maffei drew in 1709 or so and the action that we see in the 1722 and 1726 pianos as well as in several later instruments whose actions were evidently copied from Cristofori's, such as instruments by Gottfried and Johann Heinrich Silbermann, Manuel (?) Antunes, and Giovanni Ferrini. I will return to that matter in a future installment.

Notes

1. *Piano 300: Three Hundred Years of People and Pianos* was arranged by the Smithsonian's National Museum of American History and mounted in the International Gallery in the S. Dillon Ripley Center, opening on March 9, 2000, and closing on October 21, 2001. A catalog of the exhibit, *Piano 300: Celebrating Three Centuries of People and Pianos* (Washington: National Museum of American History, Behring Center, Smithsonian Institution, and NAMM—International Music Products Association, 2001) is now available. Along with Cynthia Adams Hoover and Patrick Rucker, I was privileged to be a curator of the exhibit and co-author of the book. The title, of course, reflects the fact that the piano was invented in or about 1700. My own opinion favors "in," as I explain in the second edition of *Giraffes, Black Dragons and Other Pianos* (Stanford University Press, 2001, pp. 33-35).
2. Luisa Cervelli, *La Galleria Armonica: Catalogo del Museo degli Strumenti Musicali di Roma* (Roma: Istituto Poligrafico e Zecca dello Stato, 1994), p. 142.
3. As some readers may know, Thomas Wolf suffered a serious injury to his right hand in the summer of 2001, which set back this work until rehabilitation permits it to proceed.
4. The instrument is not playable, and we could only imagine how it sounded.
5. Scipione Maffei, "Nuovo invenzione d'un gravecembalo col piano e forte; aggiunte alcune considerazioni sopra gli strumenti musicali," *Giornale de' letterati d'Italia V* (Venice, 1711), pp. 144-159. Stewart Pollens, *The Early Pianoforte* (Cambridge: Cambridge University Press, 1995), reprints the Italian text in Appendix 3, pp. 238-243, and gives an English translation on pp. 57-62. Maffei's article was the first published work referring unmistakably to the piano.

6. The certificate is quoted by Michael Kent O'Brien, "Bartolomeo Cristofori at Court in Late Medici Florence" (diss., Catholic University of America, 1994), p. 2, n. 1.
7. The manuscript is in the Biblioteca Capitolare in Verona, cod. DCCCCLX, fasc. VI, no. 1. Pollens gives an English translation of the notes in Appendix 2, pp. 232-235, and the Italian text on pp. 235-237.
8. In fact, Maffei did not quote this remark in his article. Ferdinando subsidized the journal, and Maffei may have decided not to show Cristofori's independence of his employer-prince.
9. See James Parakilas in James Parakilas, ed., *Piano Roles: Three Hundred Years of Life with the Piano* (New Haven and London: Yale University Press, 1999), p. 9.
10. *Giraffes*, p. 37. But in the paperback edition, now available, I have corrected the remark to say he "surely knew."
11. Pollens, chaps. 1-2, pp. 7-42. Konstantin Restle, *Bartolomeo Cristofori und die Anfänge des Hammerclaviers* (Munich: Editio Maris, 1991). See also Restle, "Faszination Klavier: Die Erfolgsgeschichte des Pianoforte," in Restle, ed., *Faszination Klavier: 300 Jahre Pianofortebau in Deutschland* (Munich: Prestel Verlag, 2000), pp. 81-83. This book is a magnificent catalog of an exhibit during 2000 in the Musikinstrumenten-Museum of the Staatlichen Institut für Musikforschung Preussischer Kulturbesitz in Berlin.
12. Sybil Marcuse, *Musical Instruments: A Comprehensive Dictionary*, corrected ed. (New York: W. W. Norton, 1975), s.v. "Geigenwerk," pp. 202-203. See also Marcuse, *A Survey of Musical Instruments* (New York: Harper & Row, 1975), p. 312. The instrument was also listed in an inventory of Medici instruments in 1640 (Pollens, p. 45), but for reasons unknown it does not appear in the 1700 inventory that included Cristofori's *arpicimbalo*.
13. Rosamond E. M. Harding, *The Piano-Forte: Its History Traced to the Great Exhibition of 1851* (Cambridge: Cambridge University Press, 1933; second ed., Old Woking: Gresham Books, 1978). Harding certainly produced the finest action diagrams in the literature.
14. *Giraffes*, p. 2
15. Pollens, pp. 235 (English translation), 237 (Italian text).
16. Pantaleon Hebenstreit (1668-1750), the famous hammer dulcimer (German *Hackbrett*) virtuoso, carried an enormous, specially-constructed instrument across northern Europe from about 1697 until his retirement from active work in 1733. See "Hebenstreit, Pantaleon," in *New Grove Dictionary of Music and Musicians* (hereafter NG), second ed., vol. 11, pp. 302-303.
17. Thomas Wolf pointed out that the hammer butt in the Rome piano's action, with its front cut out in a semi-circle, would exactly fit the finger of a dulcimer player. Whether that explains why the hammer butt was shaped in that way, we do not know. It may have been a way of achieving the correct weight of the butt to balance the hammer, and hammer butts on the other existing Cristofori pianos are shaped differently. See the photos of hammers of all three existing Cristofori pianos in Pollens, p. 69.
18. The 1700 Medici inventory entry on the *arpicimbalo* refers to the damper lifters as *saltarelli*, the usual Italian word for harpsichord jacks. In that entry, the *saltarelli* had red cloth as the damping material, rather than the leather now in the Rome piano's action.
19. Measurements in Pollens's schematic diagram, p. 93.
20. The differences, as shown in Pollens's schematic diagram, p. 93, are relatively close among the 1722 piano, the 1725 action, and the 1726 piano, and much wider between that group and the 1720 instrument in New York. There are many reasons to recognize that the New York instrument has been considerably altered from its original conformation (see Pollens, pp. 90-92).
21. I came upon the coincidence of those two dates, 1687 and 1688, too late to work the point into my discussion of Cristofori in *Giraffes*. Other earlier inventions, such as the bow and arrow, the catapult, and the drum, also used the principle of Newton's Second Law. Those instances demonstrate again that technology is not necessarily science in action.
22. The 1726 Cristofori in Leipzig also has these blocks.
23. See *Giraffes*, p. 39.
24. A recent article by Pollens, "The Gatti-Kraus Piano Action Ascribed to Bartolomeo Cristofori," *The Galpin Society Journal LV* (2002), pp. 269-278, reports from a close inspection of this action that it has a few parts that probably came from Cristofori, but may be an attempted reconstruction (possibly even using machine tools) with a number of oddities. I will not consider it further as evidence for Cristofori's work. ❏

Making A Christmas List? Shop the PTG Store For Easy Ideas!

- ❑ PTG logo polo shirts in black and burgundy, sizes M - 2X, \$35 each, plus shipping & handling
- ❑ Navy PTG logo jackets, M - 3X, \$55 each, plus shipping & handling
- ❑ Tan RPT logo jackets, M - 3X, \$55 each, plus shipping & handling

Print your own copy of the latest PTG Store catalog by visiting www.ptg.org and clicking on "Merchandise."